

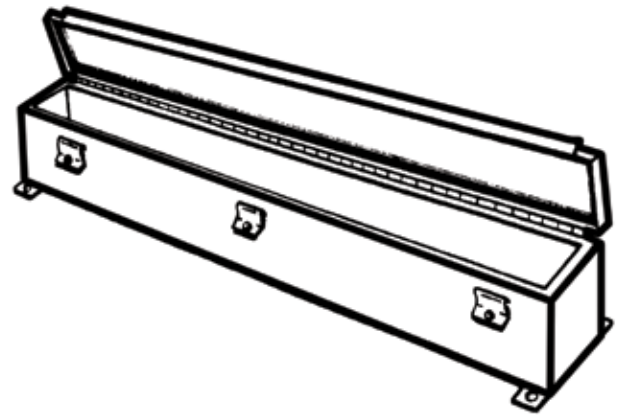

ENCLOSURES
& ENGINEERING



Serving our industry proudly for 55 years!

Standard Sizes

Height	Depth	Length	Height	Depth	Length
4	4	12	10	10	12
4	4	24	10	10	24
4	4	36	10	10	36
4	4	48	10	10	48
4	4	60	10	10	60
4	4	72	10	10	72
6	6	12	12	12	24
6	6	24	12	12	36
6	6	36	12	12	48
6	6	48	12	12	60
6	6	60	12	12	72
6	6	72			
8	8	12			
8	8	24			
8	8	36			
8	8	48			
8	8	60			
8	8	72			

NEMA 4 Hinge Cover Clamp Wireway

Application

EPI NEMA 4 JIC Hinge Cover Clamp Wireway is designed to protect wiring in areas which may be regularly hosed down or are very wet. Suitable for use outdoors, or in dairies, breweries, and similar installations.

Construction

Made from 16 or 14-gauge steel. All seams are continuously welded and there are no holes or knockouts. The covers have gasket with oil-resistant adhesive. Exterior clamps, clamp screws, and hinge pins are stainless steel and provide a complete seal between covers and bodies (Covers not to exceed 72"). Exterior mounting feet can be provided for mounting.

Finish

The standard finish is Sherwin Williams ANSI-70, light-dove gray enamel inside and out. Additional finishes are available.

Industry Standard

Meets National Electrical Manufacturers Association (NEMA) standard for Type 4 (Water Tight and Dust Tight), Type 12 (Industrial Use), and Type 12 (Oil Tight and Dust Tight) enclosures. Also conforms to the Joint Industrial Council (JIC) EGP-1-1967.