

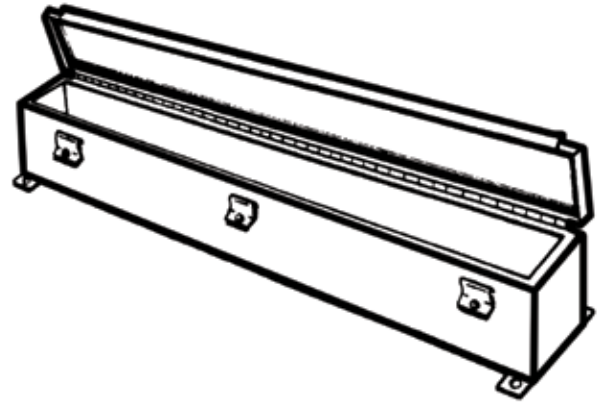

ENCLOSURES
& ENGINEERING



Serving our industry proudly for 55 years!

Standard Sizes

Width	Height	Length	Width	Height	Length
4	4	12	10	10	24
4	4	24	10	10	36
4	4	36	10	10	48
4	4	48	10	10	60
4	4	60	10	10	72
4	4	72			
			12	12	24
6	6	12	12	12	36
6	6	24	12	12	48
6	6	36	12	12	60
6	6	48	12	12	72
6	6	60			
6	6	72			
8	8	12			
8	8	24			
8	8	36			
8	8	48			
8	8	60			
8	8	72			

NEMA 4X Hinged Cover Clamp Wireway

Application

EPI NEMA 4X JIC Hinge Cover Clamp Wireway is designed to protect electrical wiring in areas which may be regularly hosed down or are very wet. Designed for use in areas where serious corrosion problems exist. Suitable for use outdoors, or in dairies, breweries, petrochemical plants, food processing plants, water treatment plants, packing plants, and similar installations.

Construction

Made from 16 and 14 gauge stainless steel (type 304). All seams are continuously welded and there are no holes or knockouts. The covers have gasket with oil resistant adhesive (Covers not to exceed 72"). Exterior clamps, clamp screws, and hinges are stainless steel and provide a complete seal between covers and bodies. Exterior mounting feet can be provided for mounting.

Finish

The standard finish is Type 304 2B Stainless Steel. All corners are ground smooth, polished and free of sharp edges. Type 316 Stainless Steel is also available.

Industry Standard

Meets National Electrical Manufacturers Association (NEMA) standard for Type 4 (Water Tight and Dust Tight), Type 4X (Water Tight, Dust Tight, and Corrosion-Resistant), Type 12 (Industrial Use), and Type 13 (Oil Tight and Dust Tight) enclosures. Also conforms to the Joint Industrial Council (JIC) standard EGP-1-1967.