

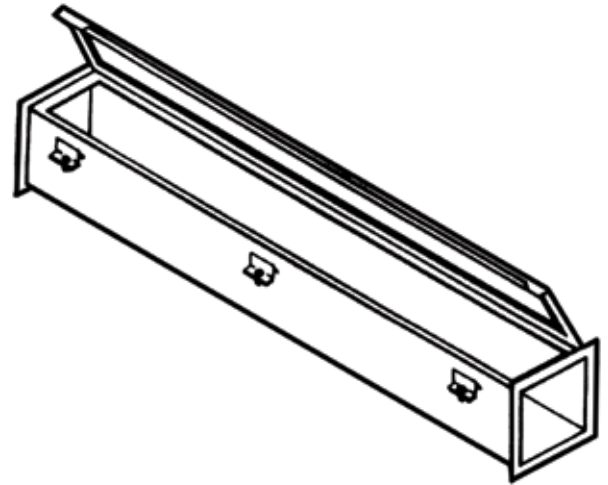

ENCLOSURES  
& ENGINEERING



Serving our industry proudly for 55 years!



## Standard Sizes

Width	Height	Length	Width	Height	Length
4	4	12	6	6	12
4	4	24	6	6	24
4	4	36	6	6	36
4	4	48	6	6	48
4	4	60	6	6	60
4	4	72	6	6	72
4	4	120	6	6	120
4x4 90° Elbow			6x6 90° Elbow		
4x4 45° Elbow			6x6 45° Elbow		
4x4 End Plate			6x6 End Plate		
4x4 Tee			6x6 Tee		
4x4 6" Long Nipple			6x6 6" Long Nipple		
4x4 Box Connector			6x6 Box Connector		
4x4 Reducer 4" to 2 1/2"			6x6 Reducer 4" to 2 1/2"		
4x4 Gasket and Screws			6x6 Gasket and Screws		
4x4 Drop Hanger			6x6 Drop Hanger		
4x4 Bracket Hanger			6x6 Bracket Hanger		

## NEMA 4X Flanged Hinged Wireway

### Application

EPI NEMA 4X JIC Stainless Steel Flanged Hinge Cover Wireway is designed to protect electrical wiring in areas, which may be regularly hosed down or are very wet. Designed for use in areas where serious corrosion problems exist. Suitable for use outdoors, or in dairies, breweries, petrochemical plants, food processing plants, sewage plants, water treatment plants, packing plants, and similar installations. A complete selection of sections and fittings is available in 4X4, 6x6, 8x8, 10x10, and 12x12 sizes.

### Construction

Made from 16 or 14-gauge stainless steel (Type 304 2B). The end flanges are made from 12-gauge stainless steel. All seams are continuously welded and there are no holes or knockouts. All sections and fittings have smooth rounded edges to prevent damage to insulation. The covers have oil resistant gasket with oil resistant adhesive. Stainless steel butt hinges and external stainless steel screw clamps assure complete seal between covers and bodies (Covers not to exceed 72"). A solid oil resistant gasket is positioned between flanges when sections and fittings are bolted together.

### Finish

The standard finish is Type 304 2B Stainless Steel. All corners are ground smooth, polished and free of sharp edges. Type 316 Stainless Steel is also available.

### Industry Standard

Meets National Electrical Manufacturers Association (NEMA) standard for Type 4 (Water Tight and Dust Tight), Type 4X (Water Tight, Dust Tight, and Corrosion Resistant) and Type 12 (Industrial Use) enclosures. Also conforms to the Joint Industrial Council (JIC) standard EGP-1-1967.



ENCLOSURES  
& ENGINEERING



Serving our industry proudly for 55 years!

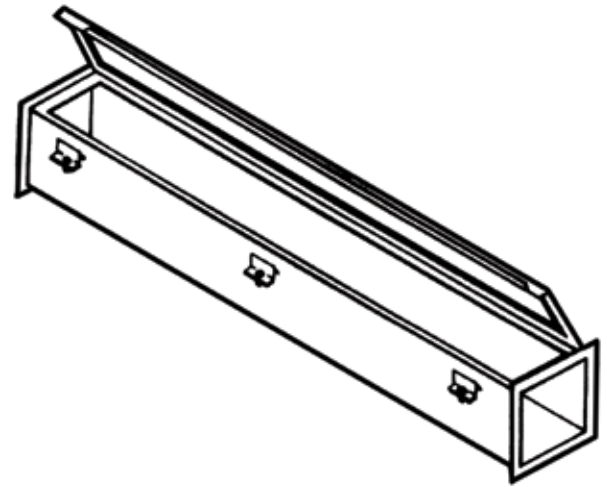

## Standard Sizes

Width	Height	Length	Width	Height	Length
8	8	12	10	10	12
8	8	24	10	10	24
8	8	36	10	10	36
8	8	48	10	10	48
8	8	60	10	10	60
8	8	72	10	10	72
8	8	120	10	10	120
8x8 90° Elbow			10x10 90° Elbow		
8x8 45° Elbow			10x10 45° Elbow		
8x8 End Plate			10x10 End Plate		
8x8 Tee			10x10 Tee		
8x8 6" Long Nipple			10x10 6" Long Nipple		
8x8 Box Connector			10x10 Box Connector		
8x8 Reducer 4" to 2 1/2"			10x10 Reducer 4" to 2 1/2"		
8x8 Gasket and Screws			10x10 Gasket and Screws		
8x8 Drop Hanger			10x10 Drop Hanger		
8x8 Bracket Hanger			10x10 Bracket Hanger		

## NEMA 4X Flanged Hinged Wireway

### Application

EPI NEMA 4X JIC Stainless Steel Flanged Hinge Cover Wireway is designed to protect electrical wiring in areas, which may be regularly hosed down or are very wet. Designed for use in areas where serious corrosion problems exist. Suitable for use outdoors, or in dairies, breweries, petrochemical plants, food processing plants, sewage plants, water treatment plants, packing plants, and similar installations. A complete selection of sections and fittings is available in 4X4, 6x6, 8x8, 10x10, and 12x12 sizes.

### Construction

Made from 16 or 14-gauge stainless steel (Type 304 2B). The end flanges are made from 12-gauge stainless steel. All seams are continuously welded and there are no holes or knockouts. All sections and fittings have smooth rounded edges to prevent damage to insulation. The covers have oil resistant gasket with oil resistant adhesive. Stainless steel butt hinges and external stainless steel screw clamps assure complete seal between covers and bodies (Covers not to exceed 72"). A solid oil resistant gasket is positioned between flanges when sections and fittings are bolted together.

### Finish

The standard finish is Type 304 2B Stainless Steel. All corners are ground smooth, polished and free of sharp edges. Type 316 Stainless Steel is also available.

### Industry Standard

Meets National Electrical Manufacturers Association (NEMA) standard for Type 4 (Water Tight and Dust Tight), Type 4X (Water Tight, Dust Tight, and Corrosion Resistant) and Type 12 (Industrial Use) enclosures. Also conforms to the Joint Industrial Council (JIC) standard EGP-1-1967.