

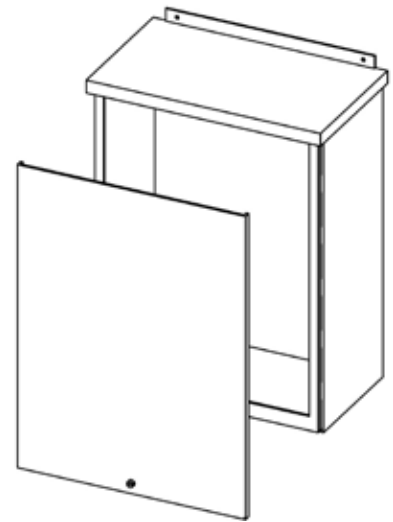

ENCLOSURES
& ENGINEERING



Serving our industry proudly for 55 years!



Standard Sizes

Width	Height	Depth	Width	Height	Depth
6	6	4	8	8	8
6	8	4	10	10	8
8	8	4	12	12	8
10	10	4	12	18	8
12	12	4	18	18	8
12	18	4	18	24	8
18	18	4	24	24	8
18	24	4			
24	24	4			
			10	10	10
6	6	6	12	12	10
6	8	6	12	18	10
8	8	6	18	18	10
10	10	6	18	24	10
12	12	6	24	24	10
18	18	6			
18	24	6	12	12	12
24	24	6	12	18	12
			12	24	12
			18	18	12
			18	24	12
			24	24	12

NEMA 3R Screw Cover Enclosure

Application

EPI NEMA 3R Screw Cover Enclosures are used to protect wiring in outdoor installations. Designed to protect the enclosed equipment against falling rain and sleet; may be used indoors where dripping water is a problem.

Construction

Made from 16 or 14-gauge steel. A drip shield top and smooth seam-free sides, front and back prevents rain, snow or sleet from entering the enclosure. The slip on removable cover is securely fastened with screws along the bottom edge. Continuous mounting feet are installed top and bottom. No gasket is provided. Panels must be ordered separately. Available in Aluminum and Stainless Steel.

Finish

The standard finish is G-90 galvanized steel. A Sherwin Williams ANSI-70 light-dove gray enamel finish inside and out is also available

Industry Standard

Meets National Electrical Manufacturers Association (NEMA) standard for Type 3R (Rainproof and Sleet-Ice Resistant) enclosures. UL50 Certification pending.