

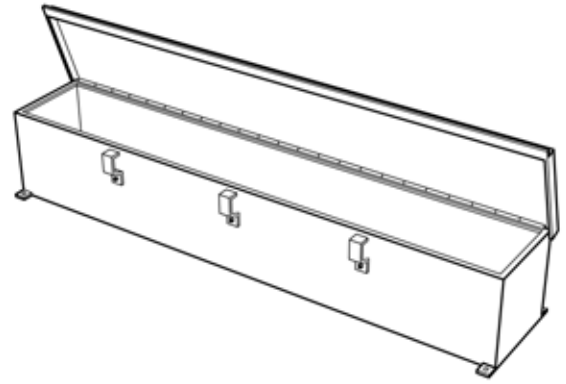

ENCLOSURES
& ENGINEERING



Serving our industry proudly for 55 years!



Standard Sizes

Height	Depth	Length	Height	Depth	Length
4	4	12	10	10	24
4	4	24	10	10	36
4	4	36	10	10	48
4	4	48	10	10	60
4	4	60	10	10	72
4	4	72			
			12	12	24
6	6	12	12	12	36
6	6	24	12	12	48
6	6	36	12	12	60
6	6	48	12	12	72
6	6	60			
6	6	72			
8	8	12			
8	8	24			
8	8	36			
8	8	48			
8	8	60			
8	8	72			

NEMA 12 Hinge Cover Wireway

Application

EPI NEMA Type 12 JIC Hinge Cover Wireway is designed to protect wiring from dust, dirt, oil, and water. For indoor use.

Construction

Made from 16 or 14-gauge steel. All seams are continuously welded and there are no holes or knockouts. Each cover has an oil-resistant gasket attached with oil resistant adhesive. Continuous stainless steel hinges and external screw clamps insure a complete seal between covers and bodies (Covers not to exceed 72"). External feet can be provided for mounting.

Finish

The standard finish is Sherwin Williams ANSI-70, light-dove gray inside and out.

Industry Standard

Meets National Electrical Manufacturers Association (NEMA) standard for Type 12 (Industrial Use) and Type 13 (Oil tight and dust tight) enclosures. Also conforms to the Joint Industrial Council (JIC) standard EGP-1-1967.

UL50E Certification pending.