

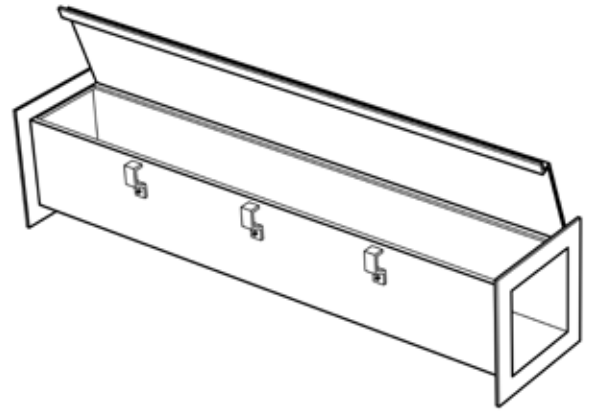

ENCLOSURES  
& ENGINEERING



Serving our industry proudly for 55 years!



## Standard Sizes

Height	Depth	Length	Height	Depth	Length
4	4	12	6	6	12
4	4	24	6	6	24
4	4	36	6	6	36
4	4	48	6	6	48
4	4	60	6	6	60
4	4	72	6	6	72
4	4	120	6	6	120

4x4 90° Elbow
4x4 45° Elbow
4x4 End Plate
4x4 Tee
4x4 6" Long Nipple
4x4 Box Connector
4x4 Reducer 4" to 2 1/2"
4x4 Gasket and Screws
4x4 Drop Hanger
4x4 Bracket Hanger

6x6 90° Elbow
6x6 45° Elbow
6x6 End Plate
6x6 Tee
6x6 6" Long Nipple
6x6 Box Connector
6x6 Reducer 4" to 2 1/2"
6x6 Gasket and Screws
6x6 Drop Hanger
6x6 Bracket Hanger

## NEMA 12 Flanged Hinged Wireway

### Application

EPI NEMA Type 12 JIC Hinge Cover Wireway is designed to protect wiring from dust, dirt, oil, and water. For indoor use.

### Construction

Made from 16 or 14-gauge steel. All seams are continuously welded and there are no holes or knockouts. Each cover has an oil-resistant gasket attached with oil resistant adhesive. Continuous stainless steel hinges and external screw clamps insure a complete seal between covers and bodies (Covers not to exceed 72"). External feet can be provided for mounting.

### Finish

The standard finish is Sherwin Williams ANSI-70, light-dove gray inside and out.

### Industry Standard

Meets National Electrical Manufacturers Association (NEMA) standard for Type 12 (Industrial Use) and Type 13 (Oil tight and dust tight) enclosures. Also conforms to the Joint Industrial Council (JIC) standard EGP-1-1967.

UL50E Certification pending.



ENCLOSURES  
& ENGINEERING



Serving our industry proudly for 55 years!

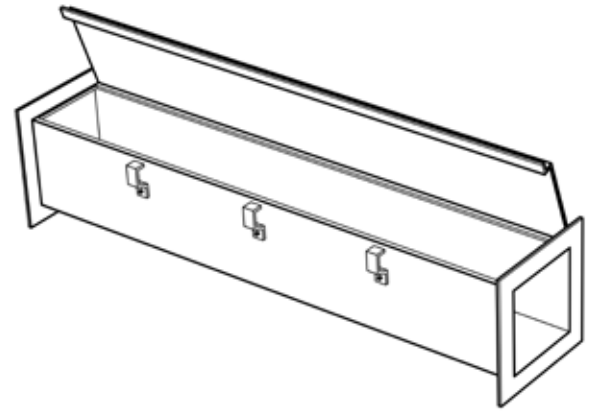

## Standard Sizes

Height	Depth	Length	Height	Depth	Length
8	8	12	10	10	12
8	8	24	10	10	24
8	8	36	10	10	36
8	8	48	10	10	48
8	8	60	10	10	60
8	8	72	10	10	72
8	8	120	10	10	120

8x8 90° Elbow
8x8 45° Elbow
8x8 End Plate
8x8 Tee
8x8 6" Long Nipple
8x8 Box Connector
8x8 Reducer 4" to 2 1/2"
8x8 Gasket and Screws
8x8 Drop Hanger
8x8 Bracket Hanger

10x10 90° Elbow
10x10 45° Elbow
10x10 End Plate
10x10 Tee
10x10 6" Long Nipple
10x10 Box Connector
10x10 Reducer 4" to 2 1/2"
10x10 Gasket and Screws
10x10 Drop Hanger
10x10 Bracket Hanger

## NEMA 12 Flanged Hinged Wireway

### Application

EPI NEMA Type 12 JIC Hinge Cover Wireway is designed to protect wiring from dust, dirt, oil, and water. For indoor use.

### Construction

Made from 16 or 14-gauge steel. All seams are continuously welded and there are no holes or knockouts. Each cover has an oil-resistant gasket attached with oil resistant adhesive. Continuous stainless steel hinges and external screw clamps insure a complete seal between covers and bodies (Covers not to exceed 72"). External feet can be provided for mounting.

### Finish

The standard finish is Sherwin Williams ANSI-70, light-dove gray inside and out.

### Industry Standard

Meets National Electrical Manufacturers Association (NEMA) standard for Type 12 (Industrial Use) and Type 13 (Oil tight and dust tight) enclosures. Also conforms to the Joint Industrial Council (JIC) standard EGP-1-1967.

UL50E Certification pending.