

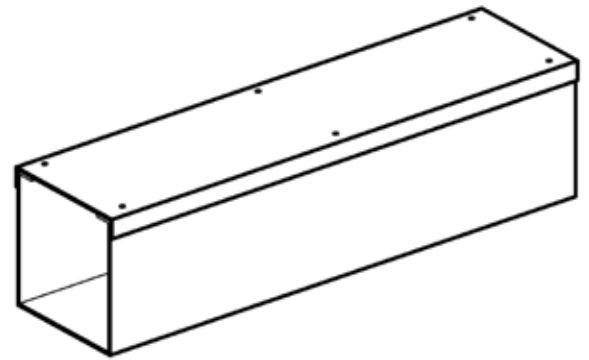

ENCLOSURES  
& ENGINEERING



Serving our industry proudly for 55 years!



## Standard Sizes

Height	Depth	Length	Height	Depth	Length
4	4	12	10	10	12
4	4	24	10	10	24
4	4	36	10	10	36
4	4	48	10	10	48
4	4	60	10	10	60
4	4	72	10	10	72
4	4	120	10	10	120
6	6	12	12	12	12
6	6	24	12	12	24
6	6	36	12	12	36
6	6	48	12	12	48
6	6	60	12	12	60
6	6	72	12	12	72
6	6	120	12	12	120
8	8	12			
8	8	24			
8	8	36			
8	8	48			
8	8	60			
8	8	72			
8	8	120			

## NEMA 1 Screw Cover Wireway

### Application

EPI NEMA Type 1 Screw Cover and Hinge Cover Wireway are designed to house electrical wiring in installations where dirt, oil, and water are not serious problems. All sections and fittings can be laid in along an entire wireway run. A complete selection of sections and fittings is available.

### Construction

The screw cover wireway comes with a single full size cover fastened with screws (Covers not to exceed 72"). The hinge cover wireway is provided with continuous sections of hinge at proper intervals. Covers can be rapidly opened or closed, and are firmly held shut with screws. Wireway covers and bodies are fabricated from 16, 14 or 10-gauge steel and galvanized steel. Available with a flush cover. Available in Aluminum and Stainless Steel.

### Finish

The standard finish is G-90 galvanized steel. A Sherwin Williams ANSI-70, light-dove gray painted enamel finish is also available inside and out.

### Industry Standard

Meets National Electrical Manufacturers Association (NEMA) standard for Type 1 (General Purpose) enclosure  
UL50 Certification pending.

### Medical Duct

EPI can supply you with your medical duct needs. Contact us for more information.